

LT2216 CM

Spare parts

Ersatzteile

Pièces détachées

Reserve onderdelen

Repuestos

Reservdelar

GPL®

ILLUSTRATED PARTS LIST

MFG. ID NO. 96061019304

CUSTOMER CATALOG NO. LT2216CM

PRODUCT NO. 960 61 01-93

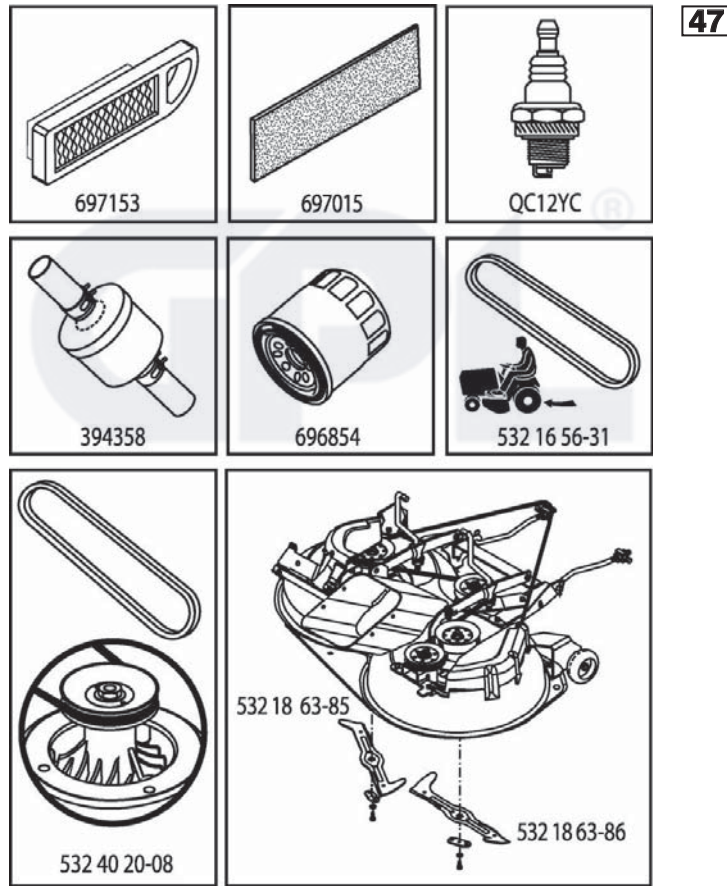

413431

**TRACTOR - - MODEL NO. LT2216CM (96061019304), PRODUCT NO. 960 61 01-93
DECALS 27**

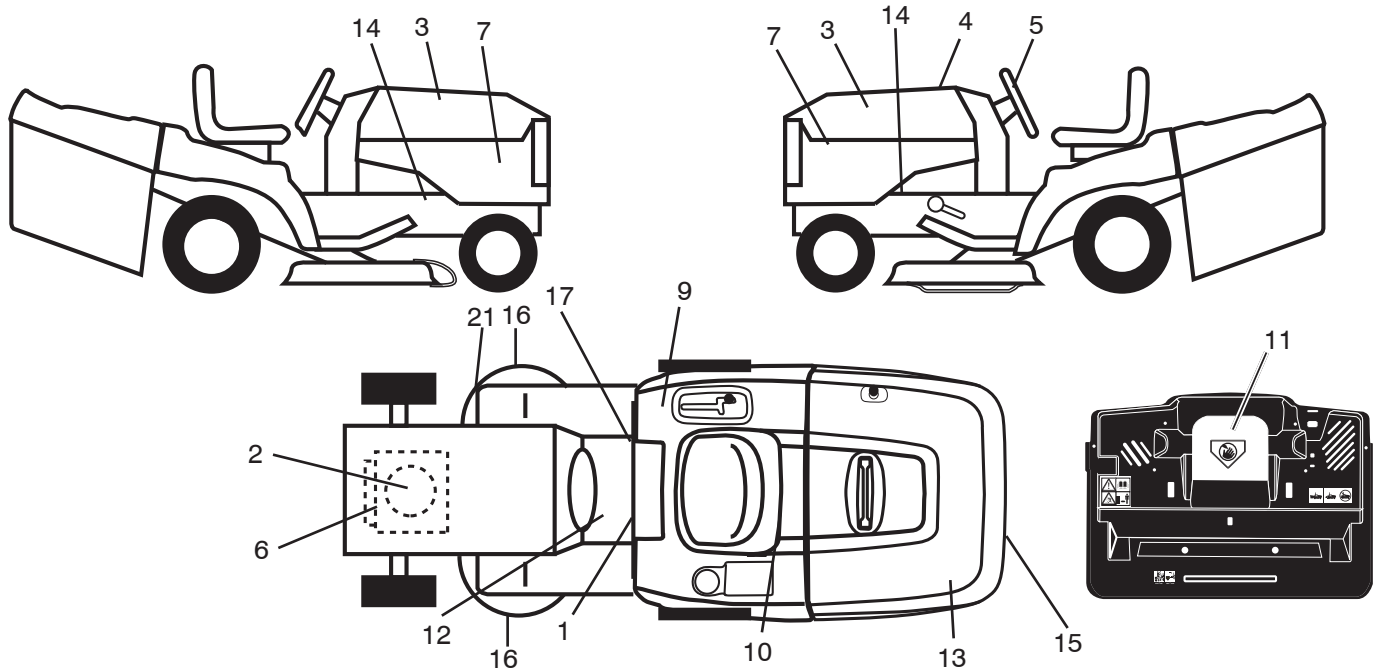

KEY NO.	PART NO.	DESCRIPTION	KEY NO.	PART NO.	DESCRIPTION
1	532 40 03-89	Decal Warning Sym. CE	15	532 18 39-30	Decal Cover Belt Guard
2	532 19 68-41	Decal Warning Eng. Sym.	16	532 19 68-42	Decal Warning Cutfinger
3	532 18 95-53	Decal Hood	17	532 14 08-37	Decal Saddle Brake Parking
4	532 41 34-31	Decal Replacement	21	532 16 62-86	Decal Hex Belt Sch 92 CRD
5	532 18 57-73	Decal Wheel Steering	--	532 13 83-11	Decal Lift Handle
6	532 40 91-50	Decal Engine HP	--	532 18 04-35	Decal Rear Plate CRD Symbols
7	532 40 85-33	Decal Side Panel	--	532 18 10-90	Pad Footrest RH
9	532 18 04-32	Decal Fender Logo	--	532 18 10-91	Pad Footrest LH
10	532 14 50-05	Decal Bat Dan/Poi P/L Sym Wpn	--	532 40 83-03	Manual Operator's (Euro)
11	532 18 21-66	Decal Mower Cut Finger Symbol	--	532 40 83-05	Manual Operator's (Scan)
12	532 15 97-37	Decal Brake/Clutch Symbol Lt	--	532 40 83-06	Manual Operator's (E-Bloc)
13	532 18 39-31	Decal Bagger	--	532 40 83-07	Manual Operator's (Baltic)
14	532 15 97-36	Decal Chassis Hot Muffler			

WHEELS & TIRES

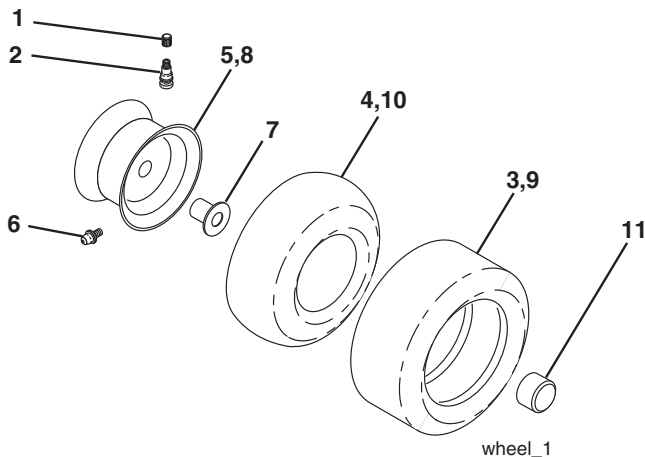

KEY NO.	PART NO.	DESCRIPTION
1	532 05 91-92	Cap Valve Tire
2	532 06 51-39	Stem Valve
3	532 10 62-22	Tire F Ts 15 x 6 0 - 6
4	532 05 99-04	Tube Inner Front #35060
5	532 13 83-36	Rim Asm 6" Front Silver
6	532 12 49-57	Fitting Grease
7	532 12 49-59	Bearing Flange
8	532 13 83-37	Rim Asm 8" Rear Silver
9	532 10 62-68	Tire R Ts 18 x 9-8 Turf Saver
--	532 42 05-31	Tire R Ts 18 x 9-8 Turf Saver LT
10	532 12 49-26	Tube Rear 9 5 x 8
11	532 17 50-39	Cap Axle Blk 1 50 x 1 00
--	532 14 43-34	Sealant, Tire (10 oz. Tube)

NOTE: All component dimensions given in U.S. inches
1 inch = 25.4 mm

TRACTOR - - MODEL NO. LT2216CM (96061019304), PRODUCT NO. 960 61 01-93 SCHEMATIC **38**

SCH08

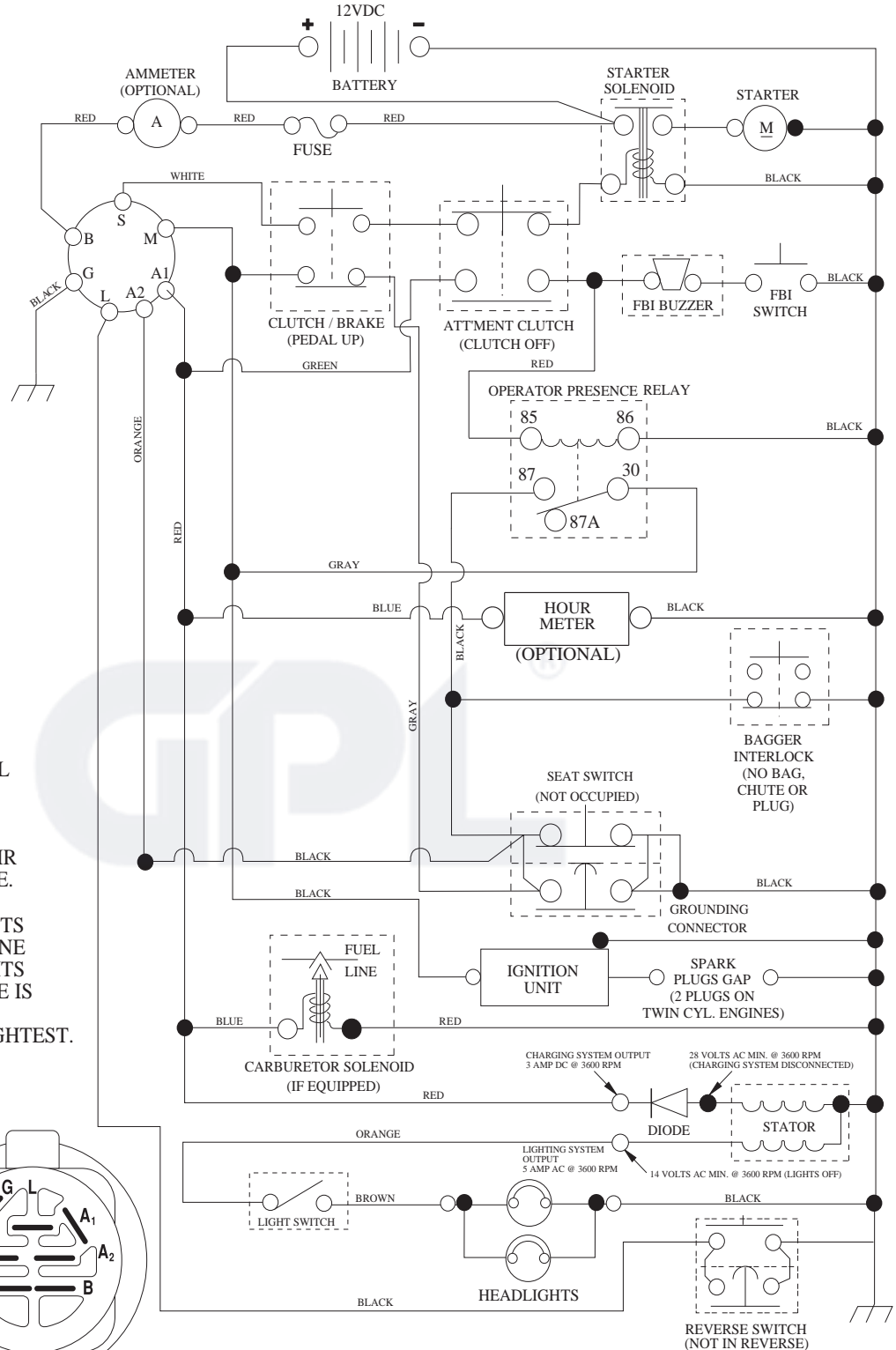

NOTE
YOUR TRACTOR IS EQUIPPED WITH A SPECIAL ALTERNATOR SYSTEM. THE LIGHTS ARE NOT CONNECTED TO THE BATTERY, BUT HAVE THEIR OWN ELECTRICAL SOURCE. BECAUSE OF THIS, THE BRIGHTNESS OF THE LIGHTS WILL CHANGE WITH ENGINE SPEED. AT IDLE THE LIGHTS WILL DIM. AS THE ENGINE IS SPEEDED UP, THE LIGHTS WILL BECOME THEIR BRIGHTEST.

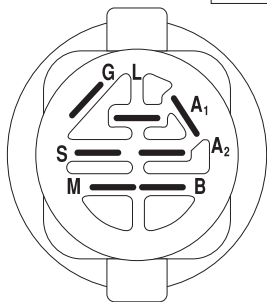

IGNITION SWITCH

POSITION	CIRCUIT	"MAKE"
OFF	M+G+A1	
RUN/OVERRIDE	B+A1	
RUN	B+A1	L+A2
START	B + S + A1	

WIRING INSULATED CLIPS
NOTE: IF WIRING INSULATED CLIPS WERE REMOVED FOR SERVICING OF UNIT, THEY SHOULD BE RE-INSTALLED TO PROPERLY SECURE YOUR WIRING.

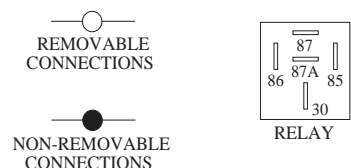

TRACTOR - - MODEL NO. LT2216CM (96061019304), PRODUCT NO. 960 61 01-93
ELECTRICAL **32**

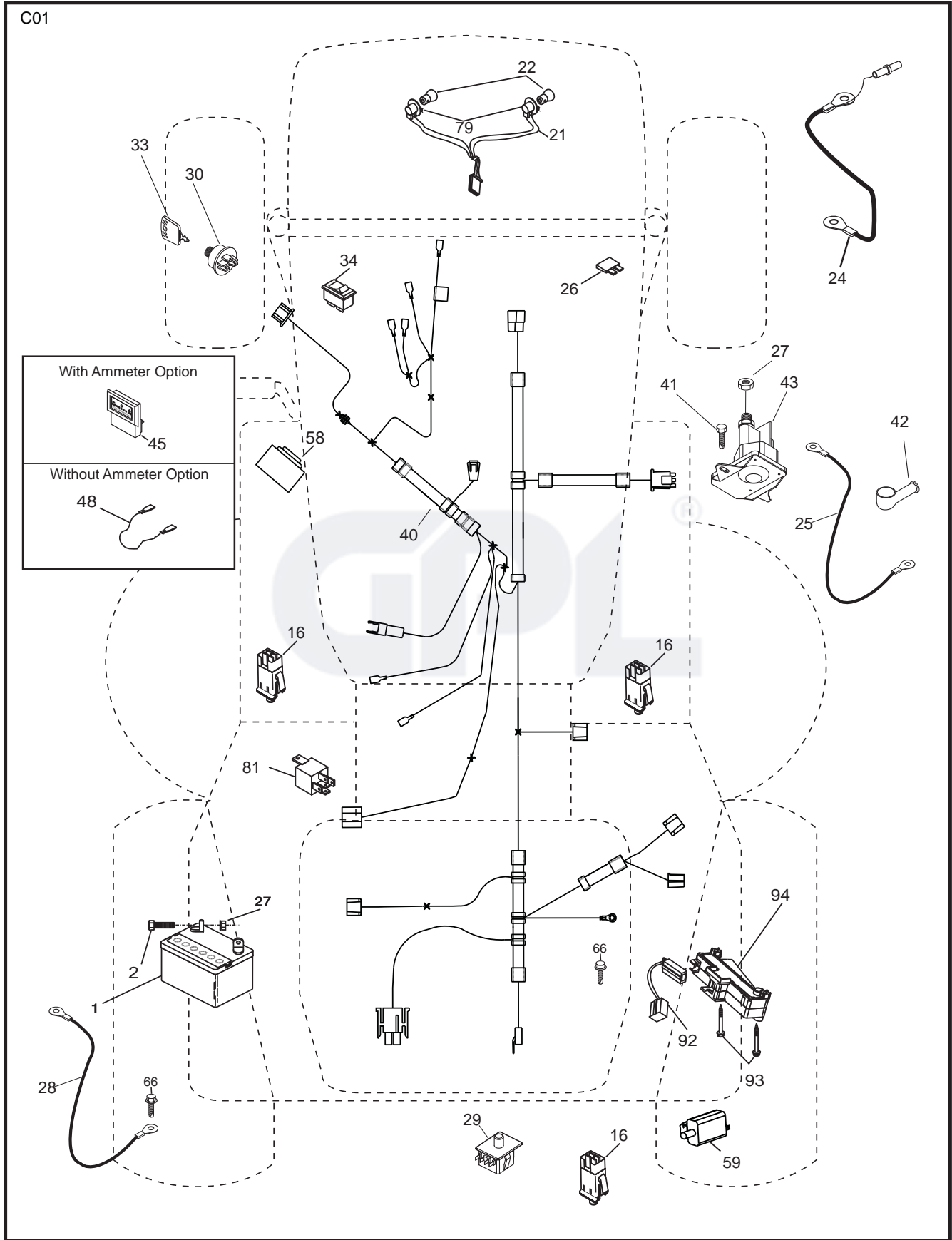

**TRACTOR - - MODEL NO. LT2216CM (96061019304), PRODUCT NO. 960 61 01-93
ELECTRICAL 32**

KEY NO.	PART NO.	DESCRIPTION
1	532 16 34-65	Battery
2	874 76 04-12	Bolt Hex Hd 1/4-20 unc x 3/4
16	532 17 61-38	Switch Interlock
21	532 18 37-59	Harness Asm Light w/4152J
22	532 00 41-52	Bulb Light #1156
24	532 12 47-80	Cable Starter
25	532 16 59-87	Cable Battery CRD 56" Red
26	532 17 51-58	Fuse
27	873 51 04-00	Nut Keps Hex 1/4-20 unc
28	532 12 77-25	Cable Ground 6 Ga. 18" Black
29	532 19 27-49	Switch Seat
30	532 19 33-50	Switch Ignition
33	532 41 19-35	Key/Chain
34	532 11 07-12	Switch Light
40	532 19 74-36	Harness Ignition
41	871 11 04-08	Bolt Flk Fin Hex 1/4-20 unc x 1/2
42	532 13 15-63	Cover Terminal Red
43	532 19 25-07	Solenoid
48	532 14 08-44	Adapter Ammeter Rectangular
58	532 16 94-19	Buzzer CRD
59	532 18 03-79	Switch FBI CRD
66	817 49 06-08	Screw Thdrol 3/8-16 x 1/2 Ty-Tt
79	532 17 52-42	Socket Asm Bulb Twistlock
81	532 10 97-48	Relay Asm
92	532 19 66-15	Harness Pigtail
93	532 19 25-40	Screw Plastite 10-14 x 2.0
94	532 19 18-34	Module Reverse

NOTE: All component dimensions given in U.S. inches
1 inch = 25.4 mm

TRACTOR -- MODEL NO. LT2216CM (96061019304), PRODUCT NO. 960 61 01-93
CHASSIS AND ENCLOSURES **39**

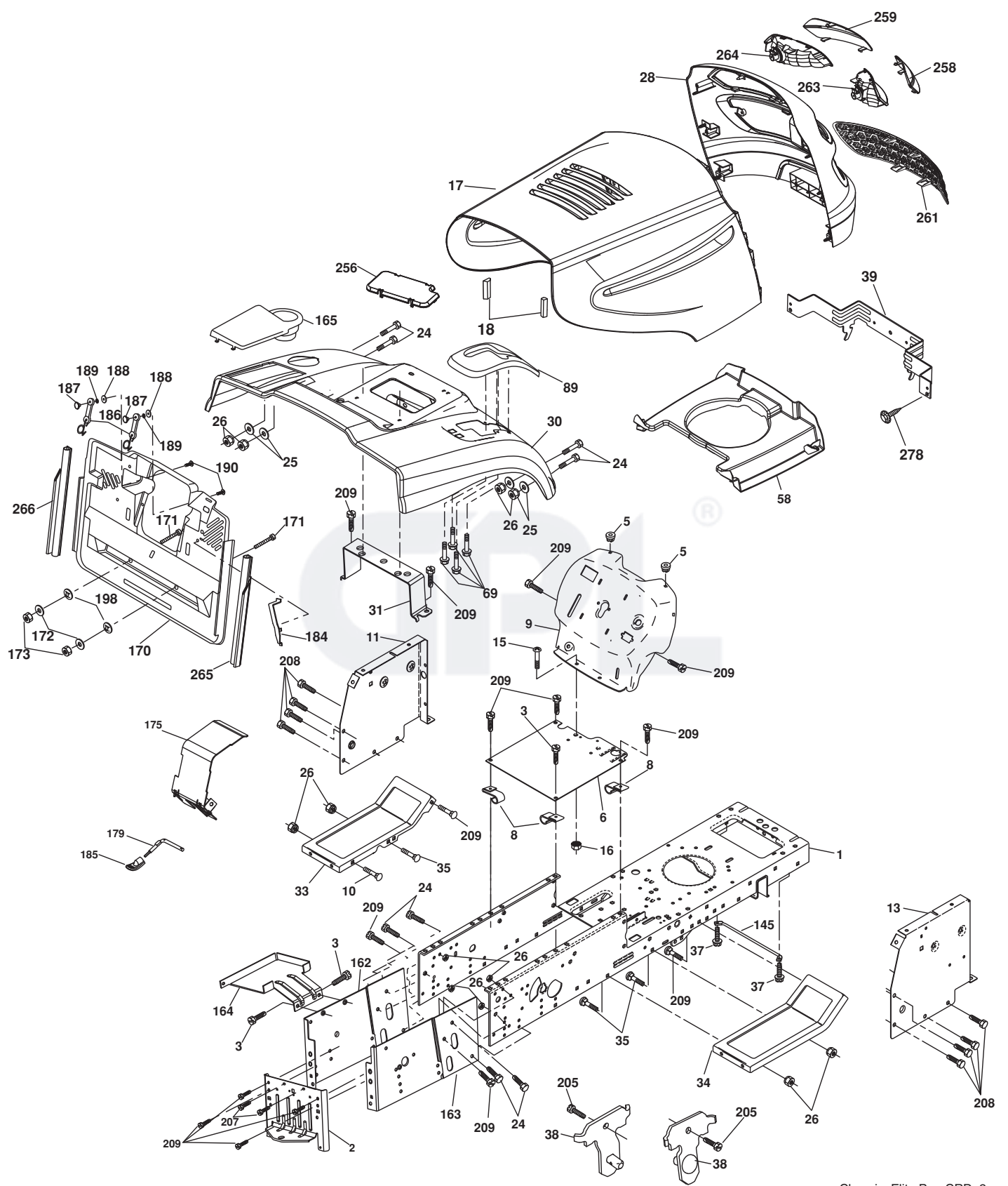

**TRACTOR - - MODEL NO. LT2216CM (96061019304), PRODUCT NO. 960 61 01-93
CHASSIS AND ENCLOSURES **39****

KEY NO.	PART NO.	DESCRIPTION	KEY NO.	PART NO.	DESCRIPTION
1	532 17 46-20	Chassis	164	532 16 56-05	Support Battery CRD
2	532 18 03-84	Drawbar	165	532 18 13-56	Cover Battery
3	817 06 06-12	Screw 3/8-16 x 3/4	170	532 19 94-88	Backplate Asm CRD
5	532 15 52-72	Bumper Hood/Dash	171	872 14 06-20	Bolt Rdhd Sqnk 3/8-16 x 2-1/2 Gr. 5
6	532 18 44-19	Saddle	172	819 13 20-16	Washer 13/32 x 1-1/4 x 16 Ga.
8	532 12 64-71	Clip Insulator 13/32 Mtg. Hole	173	873 51 06-00	Nut, Keps Hex 3/8-16 unc
9	532 19 46-88	Dash	175	532 18 82-03	Guard Trap
10	872 14 06-08	Bolt, Carriage 3/8-16 x 3/4	179	532 18 82-02	Rod Pivot FBI CRD
11	532 17 49-96	Panel, Dash, LH	184	532 17 46-62	Bracket Actuator Bagger CRD
13	532 17 52-55	Panel, Asm. Dash RH	185	532 18 11-01	Knob Rod Brake Parking
15	874 18 05-12	Screw, Machine, Truss Head 5/16-18 unc x 3/4	186	532 16 07-93	Latch Asm Mulch/Bagger
16	873 51 05-00	Nut	187	532 12 50-04	Nut Weld
17	532 19 47-57	Hood	188	819 06 12-16	Washer #10
18	532 18 49-21	Bumper Hood	189	810 07 10-00	Washer Lock #10
24	874 78 06-16	Bolt	190	871 08 10-10	Screw Pan Hd Phillip 10-24 x 5/8
25	819 13 13-12	Washer 13/32 x 13/16 x 12 Ga.	198	532 16 89-37	Nut, Push
26	873 80 06-00	Nut	205	817 49 06-08	Screw Thdrol 3/8-16 x 1/2
28	532 19 29-15	Grille /Lens Asm (Key #s 258, 259, 261, 263, 264)	207	817 67 05-08	Screw 5/16-18 x 1/2
30	532 19 73-44	Fender	208	817 67 06-08	Screw Thdrol 3/8-16 x 1/2
31	532 16 51-56	Bracket, Fender Support	209	817 00 06-12	Screw Hex Wsh Thdrol 3/8-16
33	532 18 11-93	Footrest, LH	256	532 18 13-61	Cover Fender
34	532 18 11-94	Footrest, RH	258	532 18 97-55	Lens Grille RH
35	872 11 06-06	Bolt	259	532 18 97-54	Lens Grille LH
37	817 49 05-08	Screw Thdrol 5/16-18 x 1/2 TYT	261	532 18 97-53	Insert Grille
38	532 18 17-48	Bracket Asm Pivot Mower Rear	263	532 18 38-33	Bezel Grille RH
39	532 40 78-07	Bracket Pivot	264	532 18 38-32	Bezel Grille LH
58	532 18 43-22	Duct Air	265	532 18 57-04	Seal RH Side Bagger
69	532 14 24-32	Screw Hex 1/4-1/2 unc	266	532 18 57-03	Seal LH Side Bagger
89	532 19 73-39	Console	278	532 41 63-58	Screw 10 x .750 BOS Thread
145	532 40 91-67	Rod Pivot Chassis/Hood			
162	532 18 03-82	Bracket Exten Chassis LH CRD			
163	532 18 03-83	Bracket Exten Chassis RH CRD			

NOTE: All component dimensions given in U.S. inches.
1 inch = 25.4 mm.

TRACTOR -- MODEL NO. LT2216CM (96061019304), PRODUCT NO. 960 61 01-93
DRIVE **40**

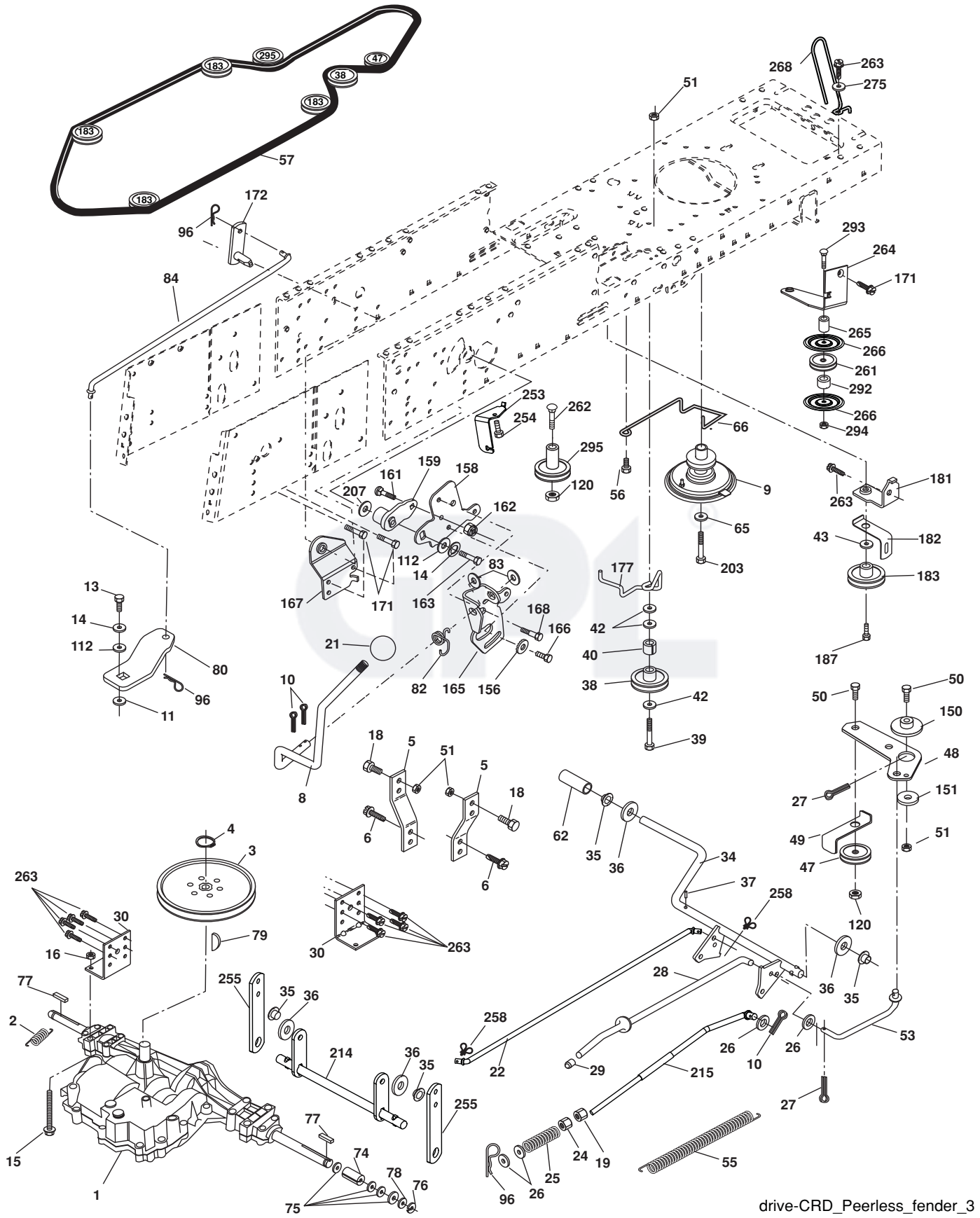

drive-CRD_Peerless_fender_3

**TRACTOR - - MODEL NO. LT2216CM (96061019304), PRODUCT NO. 960 61 01-93
DRIVE 40**

KEY NO.	PART NO.	DESCRIPTION	KEY NO.	PART NO.	DESCRIPTION
1	-----	Transaxle Peerless PMST 206-546 (Order parts from transaxle manufacturer)	78	532 12 17-48	Washer 25/32 x 1-5/8 x 16 Ga.
2	532 14 66-82	Spring Brake Return	79	532 12 50-96	Key Woodruff
3	532 16 59-99	Pulley Transaxle	80	532 14 50-90	Arm Shift PMST 20" Tires
4	812 00 00-28	Ring Retainer #5100-62	82	532 16 57-11	Spring, Torsion
5	532 12 15-20	Strap Torque 30 Degrees	83	819 17 12-16	Washer 17/32 x 3/4 x 16 Ga.
6	817 06 05-12	Screw 5/16-18 x 3/4	84	532 16 56-21	Link Shift CRD Pmst 18" Tires
8	532 19 27-06	Rod Shift Fender Adjust Lt	96	532 12 47-88	Spring, Retainer 1"
9	532 40 85-79	Clutch Asm Noram	112	819 09 12-10	Washer 9/32 x 3/4 x 10 Ga.
10	876 02 04-16	Pin, Cotter 1/8 x 1	120	873 90 06-00	Nut Lock 3/8-16
11	532 10 57-01	Washer Plate Shf .3888 Sq Hole	150	532 16 58-50	Bushing, Bellcrank Grnd Dr
13	874 55 04-12	Bolt 1/4-28 unf Gr. 8 w/Patch	151	819 13 32-10	Washer 13/32 x 2 x 10 Ga.
14	810 04 04-00	Washer, Lock Hvy Helical	156	532 16 60-02	Washer Srrd 5/16 ID x 1.125
15	874 49 05-44	Bolt Hex FGHD 5/16-18 x Gr. 5	158	532 16 55-89	Bracket Shift Mount
16	873 80 05-00	Nut, Lock Hex w/Ins 5/16-18 unc	159	532 18 39-00	Hub Tapered Flange Shift Lt
18	874 78 06-16	Bolt Hex 3/8-16 unc x 1 Gr. 5	161	872 14 04-06	Bolt Rdhd Sqnk 1/4-20 x 3/4 Gr. 5
19	873 80 06-00	Nut, Lock Hex w/Wsh 3/8-16 unc	162	873 68 04-00	Nut Crownlock 1/4-20 unc
21	532 12 12-74	Knob	163	874 78 04-16	Bolt Hex Fin 1/4-20 unc x 1 Gr. 5
22	532 17 56-07	Rod, Brake CRD Main	165	532 16 56-23	Bracket Pivot Lever
24	873 35 06-00	Nut	166	817 49 05-10	Screw 5/16-18 x 5/8
25	532 10 68-88	Spring, Rod, Brake	167	532 16 55-88	Bracket Support Shift CRD
26	819 13 13-16	Washer 13/32 x 13/16 x 16 Ga.	168	532 16 54-92	Bolt Shoulder 5/16-18 x .561
27	876 02 04-12	Pin, Cotter 1/8 x 3/4	171	817 49 06-08	Screw Thdrol 3/8-16 x 1/2 Ty-Tt
28	532 17 57-65	Rod, Parking Brake	172	532 16 56-35	Shaft Asm Shift Front CRD PMST
29	532 07 16-73	Cap, Parking Brake	177	532 16 59-32	Keeper Flat Idler 3.06" CRD
30	532 17 49-73	Bracket, Mfg. Transaxle	181	532 18 02-11	Bracket Idler Ground Drive CRD
34	532 17 55-78	Shaft, Asm Pedal Foot CRD	182	532 18 26-82	Keeper Belt 2.5" Od V-Idler CRD
35	532 12 01-83	Bearing, Nylon	183	532 19 95-32	Pulley V-Idler CRD
36	819 21 16-16	Washer 21/32 x 1 x 16 Ga.	187	817 58 05-20	Screw 5/16-18 x 1.25
37	532 12 49-63	Pin, Roll 3/16 x 1"	203	871 17 07-80	Bolt Hex 7/16-20 x 5
38	532 16 59-36	Pulley, Flat	207	532 16 98-45	Washer Nylon
39	874 76 06-44	Bolt Fin Hex 3/8-16 unc x 2-3/4	214	532 17 56-09	Shaft Asm. Brake
40	532 12 49-65	Spacer, Split 395 x 59 Bzp	215	532 41 01-42	Rod Brake Secondary
42	819 13 13-12	Washer 13/32 x 13/16 x 12 Ga.	253	532 17 50-28	Bracket Cable Chassis
43	819 11 10-12	Washer 11/32 x 5/8 x 12 Ga.	254	817 00 06-16	Screw 3/8-16 x 1
47	532 12 77-83	Pulley, Idler, V Groove Plastic	255	532 17 56-08	Brace Shaft Brake
48	532 15 44-07	Bellcrank Clutch Grnd Drv	258	532 17 80-62	Clip Retainer
49	532 12 32-05	Retainer, Belt Style Spring	261	532 13 14-94	Pulley Idler Flat Plated
50	872 11 06-12	Bolt Carr Sh 3/8-16 x 1-1/2 Gr. 5	262	872 11 06-22	Bolt Rdhd 3/8-16 unc x 2-3/4 Gr. 5
51	873 68 06-00	Nut, Crownlock 3/8-16 unc	263	817 00 06-12	Screw Hex Wsh THDR 3/8-16 x 3/4
53	532 19 96-52	Link, Clutch 7.66	264	532 19 76-08	Bracket Idler
55	532 10 57-09	Spring, Return, Clutch	265	532 40 46-07	Spacer Idler Chassis
56	817 06 06-20	Screw 3/8-16 x 1-1/4	266	532 18 20-61	Shield Idler
57	532 16 56-31	V-Belt Kev PMST CRD	268	532 18 24-02	Guard Muffler OHV B&S RH
62	532 12 48-72	Cover, Pedal	275	819 13 16-14	Washer 13/32 x 1 x 14 Ga.
65	810 04 07-00	Washer	292	532 40 02-71	Spacer Noram CRD
66	532 15 47-78	Keeper, Belt Engine F-Proof	293	872 14 06-28	Bolt RHHD SQNK 3/8-16 x 3-1/2
74	532 13 70-57	Spacer Axle	294	532 19 70-33	Nut Jam 3/8-16
75	532 12 17-49	Washer 25/32 x 1-1/4 x 16 Ga.	295	532 17 91-14	Pulley Idler Composite Ext. Hub
76	812 00 00-01	Ring, E			
77	532 12 35-83	Key, Square			

NOTE: All component dimensions given in U.S. inches
1 inch = 25.4 mm

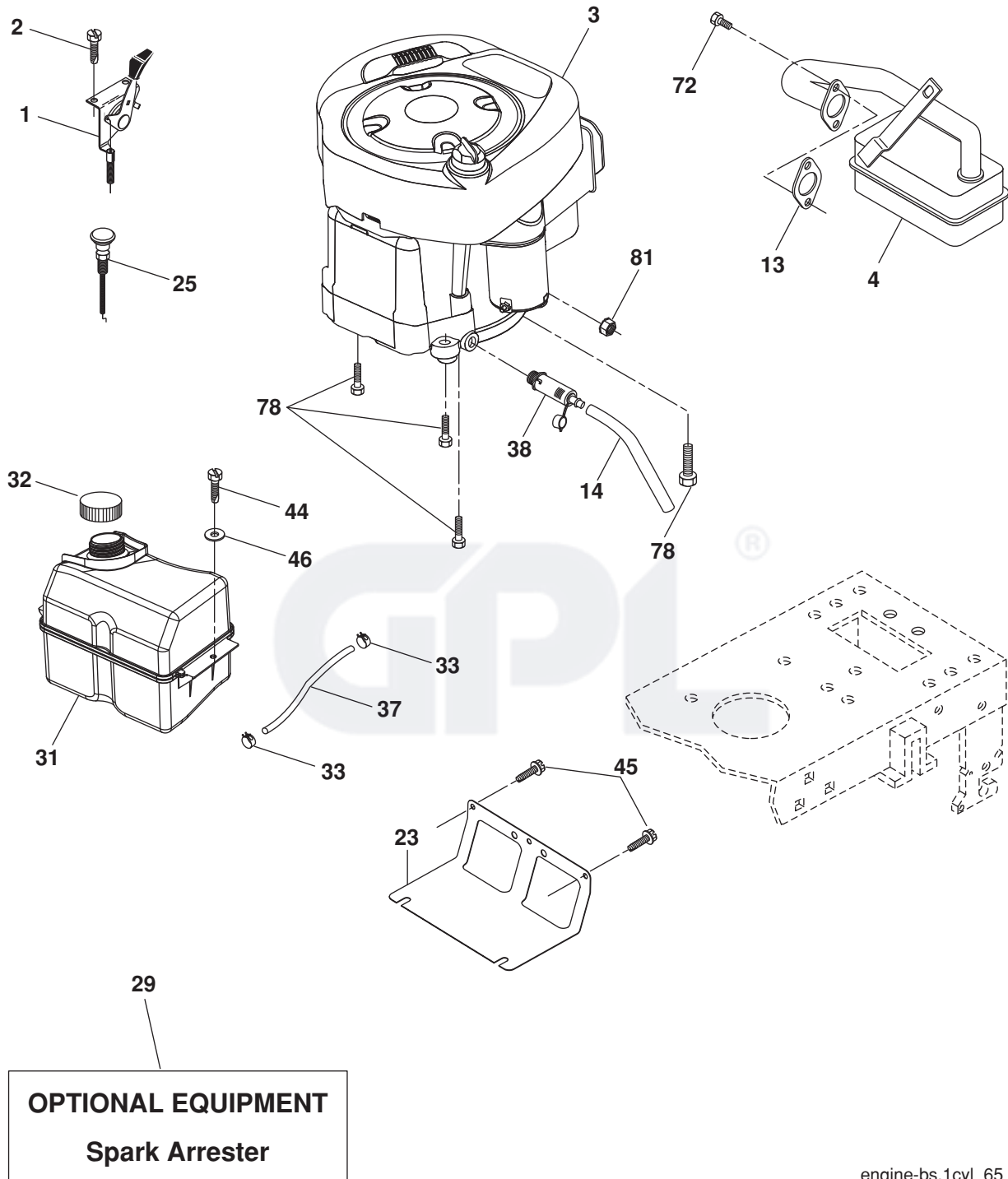

**TRACTOR - - MODEL NO. LT2216CM (96061019304), PRODUCT NO. 960 61 01-93
ENGINE 24**

KEY NO.	PART NO.	DESCRIPTION
1	532 17 05-51	Control Throt/Ck
2	817 72 04-08	Screw Hex Thd Cut 1/4-20 x 1/2
3	-----	Engine Briggs Model 31E677 (Order parts from engine manufacturer)
4	532 13 73-52	Muffler
13	532 16 52-91	Gasket Muffler
14	532 14 84-56	Tube Drain Oil Easy
23	532 16 98-37	Shield Brn/Dbr Guard
25	532 19 06-95	Control Choke
29	532 13 71-80	Kit Spark Arrestor (Flat Scrn)
31	532 40 75-51	Tank Fuel 2.00
32	532 19 77-25	Cap Asm Fuel
33	532 12 34-87	Clamp Hose Blk
37	532 13 70-40	Line Fuel
38	532 18 16-54	Plug Drain Oil Easy
44	817 67 04-12	Screw Hexwsh Thdrol 1/4-20 x 3/4
45	817 00 06-12	Screw Hexwsh Thdr 3/8-16 x 3/4
46	819 09 14-16	Washer 9/32 x 7/8 x 16 Ga.
72	532 19 23-34	Screw 5/16-18 x .75
78	817 06 06-20	Screw 3/8-16 x 1-1/4
81	873 51-04-00	Nut Keps Hex 1/4-20 unc

NOTE: All component dimensions given in U.S. inches
1 inch = 25.4 mm

Engine Power Rating Information

The Gross power rating for individual Gas engine models is labeled in accordance with SAE (Society of Automotive Engineers) code J11940 (Small Engine Power & Torque Rating Procedure), and rating performance has been obtained and corrected in accordance with SAE J1995 (Revision 2002-5). Actual Gross engine power will be lower and is affected by, among other things, ambient operating conditions and engine-to-engine variability. Given both the wide array of products on which engines are placed and the variety of environmental issues applicable to operating the equipment, the Gas engine will not develop the rated Gross power when used in a given piece of power equipment (actual "on-site" or net horsepower). This difference is due to a variety of factors including, but not limited to, accessories (air cleaner, exhaust, charging, cooling, carburetor, fuel pump, etc.), application limitations, ambient operating conditions (temperature, humidity, altitude), and engine-to-engine variability. Due to manufacturing and capacity limitations, Briggs & Stratton may substitute an engine of higher rated power for this Series engine.

TRACTOR -- MODEL NO. LT2216CM (96061019304), PRODUCT NO. 960 61 01-93
 STEERING ASSEMBLY **41**

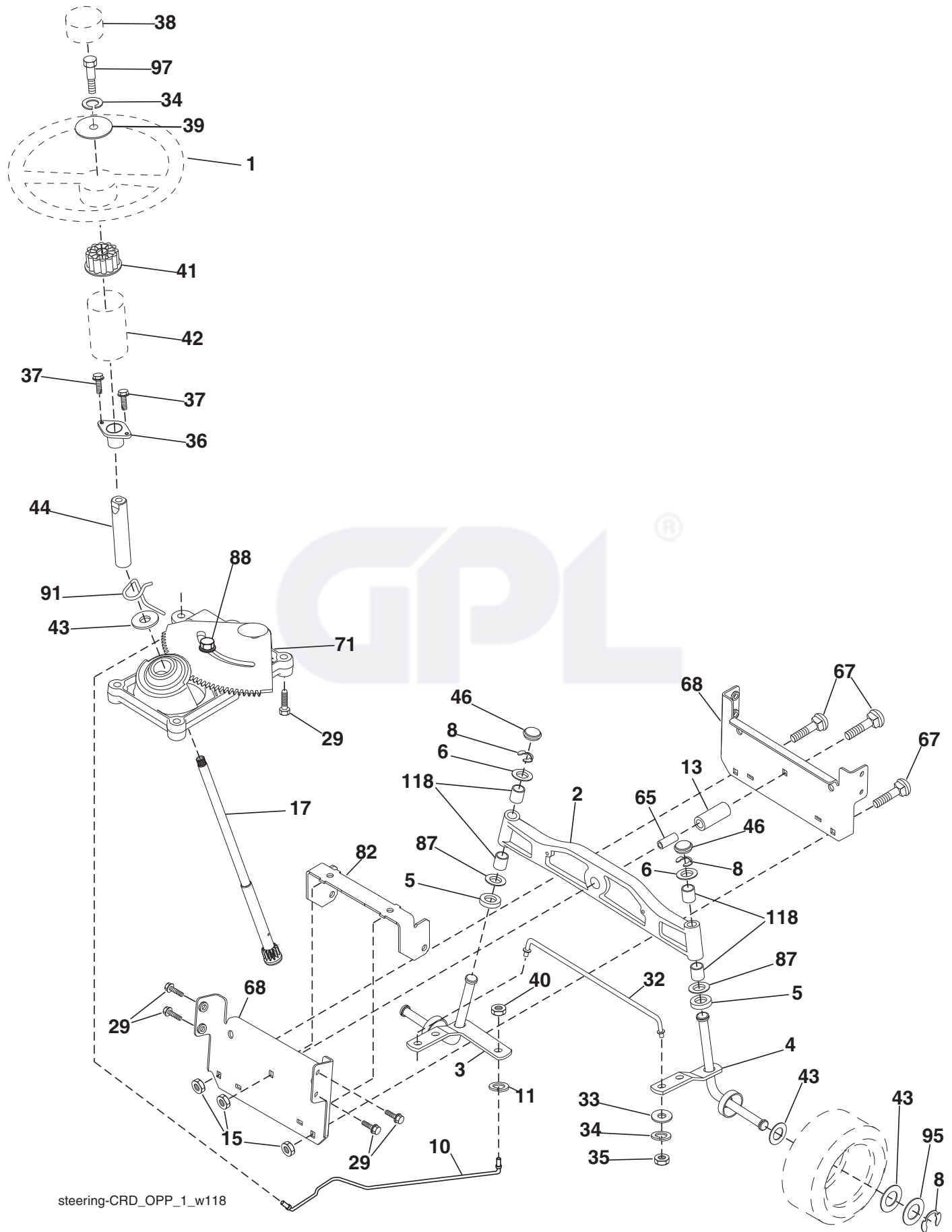

steering-CRD_OPP_1_w118

**TRACTOR - - MODEL NO. LT2216CM (96061019304), PRODUCT NO. 960 61 01-93
STEERING ASSEMBLY **41****

KEY NO.	PART NO.	DESCRIPTION
1	532 19 46-37	Steering Wheel
2	532 18 47-06	Front Axle Assembly
3	532 16 98-40	Spindle Assembly, LH
4	532 16 98-39	Spindle Assembly, RH
5	532 12 49-31	Bearing, Race, Thrust, Hardened
6	532 12 17-48	Washer 25/32 x 1-5/8 x 16 Ga.
8	812 00 00-29	Ring, Clip
10	532 17 51-21	Link, Drag
11	810 04 06-00	Washer, Lock
13	532 13 65-18	Spacer Axle
15	532 14 52-12	Nut Hex Flange Lock
17	532 19 07-53	Shaft Assembly, Steering
29	817 00 06-12	Screw 3/8-16 x 3/4
32	532 17 01-62	Rod, Tie
33	819 11 12-16	Washer 11/32 x 3/4 x 16 Ga.
34	810 04 05-00	Washer Lock Hvy Hlcl Spr 5/16
35	873 54 05-00	Crownlock Nut 5/16-24 unf
36	532 15 50-99	Bushing, Steering
37	532 15 29-27	Screw TT #10-32 x 5 x 3/8 Flange
38	532 19 46-03	Cap Wheel Steering
39	819 11 38-12	Washer 11/32 ID x 2 3/8 OD x 12 Ga.
40	873 54 06-00	Nut Crownlock 3/8-24 unf
41	532 18 67-37	Adaptor, Steering Wheel
42	532 16 96-33	Boot, Steering
43	532 12 17-49	Washer 25/32 x 1-1/4 x 16 Ga.
44	532 19 07-52	Extension Steering
46	532 12 12-32	Cap, Spindle
65	532 41 47-36	Spacer Axle
67	872 11 06-18	Bolt Rdhd Sq 3/8-16 x 2-1/4
68	532 16 98-27	Brace Axle
71	532 17 51-46	Steering Asm.
82	532 19 99-78	Bracket Susp. Chassis Front
87	532 17 39-66	Washer Flat .781 x 1-1/2 x .14
88	532 17 51-18	Bolt Shoulder 7/16-20 unc
91	532 17 55-53	Clip Steering
95	532 18 89-67	Washer
97	874 78 05-64	Bolt 5/16-18 unc x 4" L Gr. 5
118	532 40 60-13	Bushing, Metal, Axle, Cast

NOTE: All component dimensions given in U.S. inches
1 inch = 25.4 mm

TRACTOR - - MODEL NO. LT2216CM (96061019304), PRODUCT NO. 960 61 01-93
SEAT ASSEMBLY **42**

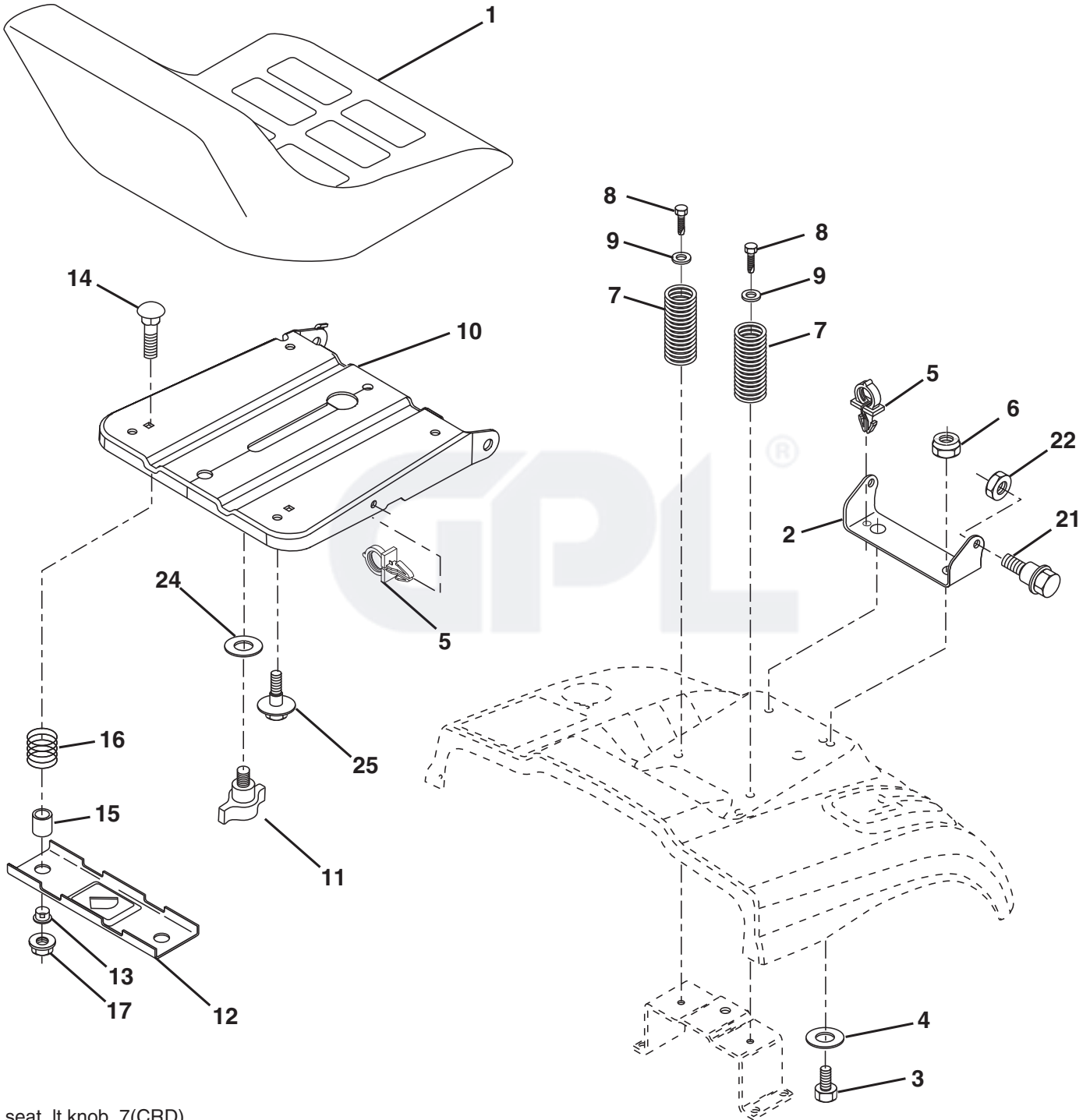

seat_lt.knob_7(CRD)

**TRACTOR - - MODEL NO. LT2216CM (96061019304), PRODUCT NO. 960 61 01-93
SEAT ASSEMBLY 42**

KEY NO.	PART NO.	DESCRIPTION
1	532 19 78-95	Seat
2	532 14 05-51	Bracket Pnt Pivot Fender
3	871 11 06-16	Bolt Fin Hex 3/8-16 x 1
4	819 13 16-10	Washer Flat 13/32 x 1 x 10 Ga.
5	532 14 50-06	Clip Push In Hinged
6	873 80 06-00	Nut Lock Hex W/Ins 3/8-16
7	532 12 41-81	Spring Seat Cprsn 2 250 Blk Zi
8	817 00 06-16	Screw 3/8-16 x 1.5
9	819 13 16-14	Washer 13/32 x 1 x 14 Ga.
10	532 19 55-30	Pan Pnt Seat
11	532 16 63-69	Knob Seat Adj. Wingnut
12	532 17 46 48	Bracket Pnt Mounting Switch
13	532 12 12-48	Bushing Snap Blk Nyl 50 Id
14	872 05 04-12	Bolt Rdhd Sht Nk 1/4-20 x 1-1/2
15	532 13 43-00	Spacer Split
16	532 12 12-50	Spring Cprsn
17	532 12 39-76	Nut Lock 1/4 Lge Flg Gr. 5 Zinc
21	532 17 18-52	Bolt Shoulder 5/16-18 unc-2A
22	873 80 05-00	Nut Hex Lock w/Ins 5/16-18
24	819 17 19-12	Washer 17/32 x 1-3/16 x 12 Ga.
25	532 12 70-18	Bolt shoulder 5/16-18 x .62

NOTE: All component dimensions given in U.S. inches
1 inch = 25.4 mm

TRACTOR -- MODEL NO. LT2216CM (96061019304), PRODUCT NO. 960 61 01-93
MOWER DECK 44

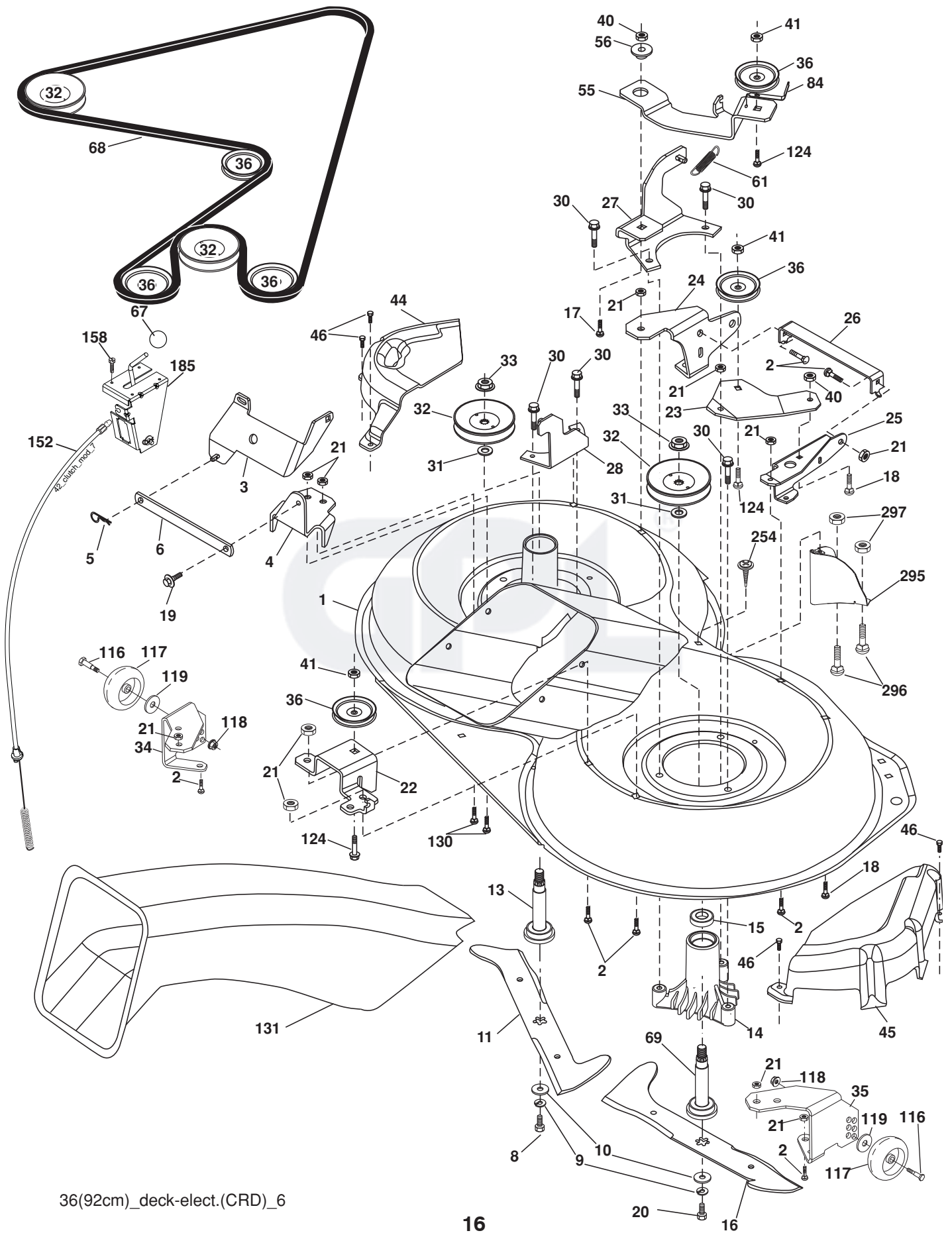

36(92cm)_deck-elect.(CRD)_6

**TRACTOR - - MODEL NO. LT2216CM (96061019304), PRODUCT NO. 960 61 01-93
MOWER DECK 44**

KEY NO.	PART NO.	DESCRIPTION	KEY NO.	PART NO.	DESCRIPTION
1	532 40 01-08	Housing Asm. Mower 92 CRD	46	532 13 77-29	Screw Thd Roll 1/4-20 x 5/8
2	872 14 05-06	Bolt Rdhd Sqnk 5/16-18 unc x 3/4	55	532 19 94-98	Arm Idler 92 CRD
3	532 16 55-69	Bracket Asm. S-Bar Chass 92 CRD	56	532 16 57-23	Spacer Retainer Mower
4	532 16 55-58	Bracket Bar Sway Deck 92 CRD	61	532 19 94-86	Spring Tension Belt
5	532 12 46-70	Retainer Spring	67	532 10 69-32	Knob Rd 3/8-16 Plstc Thds Blk
6	532 16 55-57	Bar Sway 92 CRD	68	532 40 20-08	Hex-Belt 92 Mower
8	532 18 17-12	Bolt 3/8-24 x 1.25 Gr. 8 Patched	69	532 16 54-82	Shaft Asm w/Lwr Brg RH Thd CRD
9	810 03 06-00	Washer Lock Hvy 3/8 Unplated	84	532 15 60-85	Keeper Belt Idler
10	532 14 02-96	Washer Hard Blade Vented	116	532 19 34-06	Bolt Shoulder
11	532 18 63-85	Blade 3-1 LH 92 CRD	117	532 17 48-73	Wheel Gauge
13	532 13 76-45	Shaft Asm. w/Lower Bearing	118	873 90 06-00	Nut Lock Flg 3/8-16 unc
14	532 12 87-74	Housing Mandrel Vented (Machd)	119	819 13 20-12	Washer 13/32 x 1-1/4 x 12 Ga.
15	532 11 04-85	Bearing Ball Mandrel	124	872 11 06-12	Bolt Carr Sh 3/8-16 x 1-1/2 Gr. 5
16	532 18 63-86	Blade 3-1 RH 92 CRD	130	872 11 05-06	Bolt Rdhdsqnk 5/16-18 unc x 3/4
17	872 14 06-10	Bolt Carriage 3/8-16 x 1-1/4	131	532 16 56-61	Chute Bagger CRD 92cm
18	872 11 06-06	Bolt Rdhd Sqnk 3/8-16 x 3/4	152	532 17 60-74	Cable Clutch CRD
19	532 13 28-27	Bolt Shoulder 5/16-18 Thd Form	158	817 72 04-08	Screw Hex Thd Cut 1/4-20 x 1/2
20	532 18 17-13	Bolt 3/8-24 x 1.25 Gr. 8 Ptch Lhthd	185	532 18 82-34	Head Asm. Cable Clutch
21	873 68 05-00	Nut Crown Lock 5/16-18	254	817 00 06-16	Screw 3/8-16 x 1
22	532 19 95-90	Bracket Idler Sprt 92 CRD	295	532 41 21-71	Baffle Front
23	532 16 54-46	Bracket Idler Sprt	296	872 14 04-06	Bolt RDHD SQNK 1/4-20 x 3/4 Gr. 5
24	532 16 52-42	Bracket Suspension LF 92 CRD	297	873 93 04-00	Nut Centerlock 1/4-20 unc
25	532 16 52-44	Bracket Suspension RF 92 CRD	--	532 18 18-57	Mandrel Assembly (Includes housing, shaft assembly, and bearing only - pulley/nut.washer and blade bolt/washers not included)
26	532 40 01-10	Brace Susp Frt CRD	--	532 18 18-58	Mandrel Asm CRD LH Threads SVC
27	532 16 55-68	Bracket Asm. Susp RR 92 CRD	--	532 41 37-11	Replacement Mower, Complete (Std. Deck - Order separately gauge wheel components key nos. 116 - 119)
28	532 16 55-67	Bracket Asm. Susp LR 92 CRD			
30	532 17 39-84	Screw Thd Rolling			
31	532 18 76-90	Washer Spacer Mower Vented			
32	532 15 35-32	Mandrel Pulleys			
33	532 40 02-34	Nut Flg Top Lock			
34	532 40 01-07	Bracket Gauge Wheel LF 92 CRD			
35	532 40 01-06	Bracket Gauge Wheel RF 92 CRD			
36	532 14 67-63	Pulley Idler V-Groove Dim 4.25			
40	873 68 06-00	Nut Crownlock 3/8-16 unc			
41	873 90 06-00	Nut Lock Flg. 3/8-16 unc			
44	532 17 55-38	Cover Mandrel LH 92 CRD			
45	532 17 55-39	Cover Mandrel RH 92 CRD			

NOTE: All component dimensions given in U.S. inches
1 inch = 25.4 mm

TRACTOR - - MODEL NO. LT2216CM (96061019304), PRODUCT NO. 960 61 01-93
MOWER LIFT 45

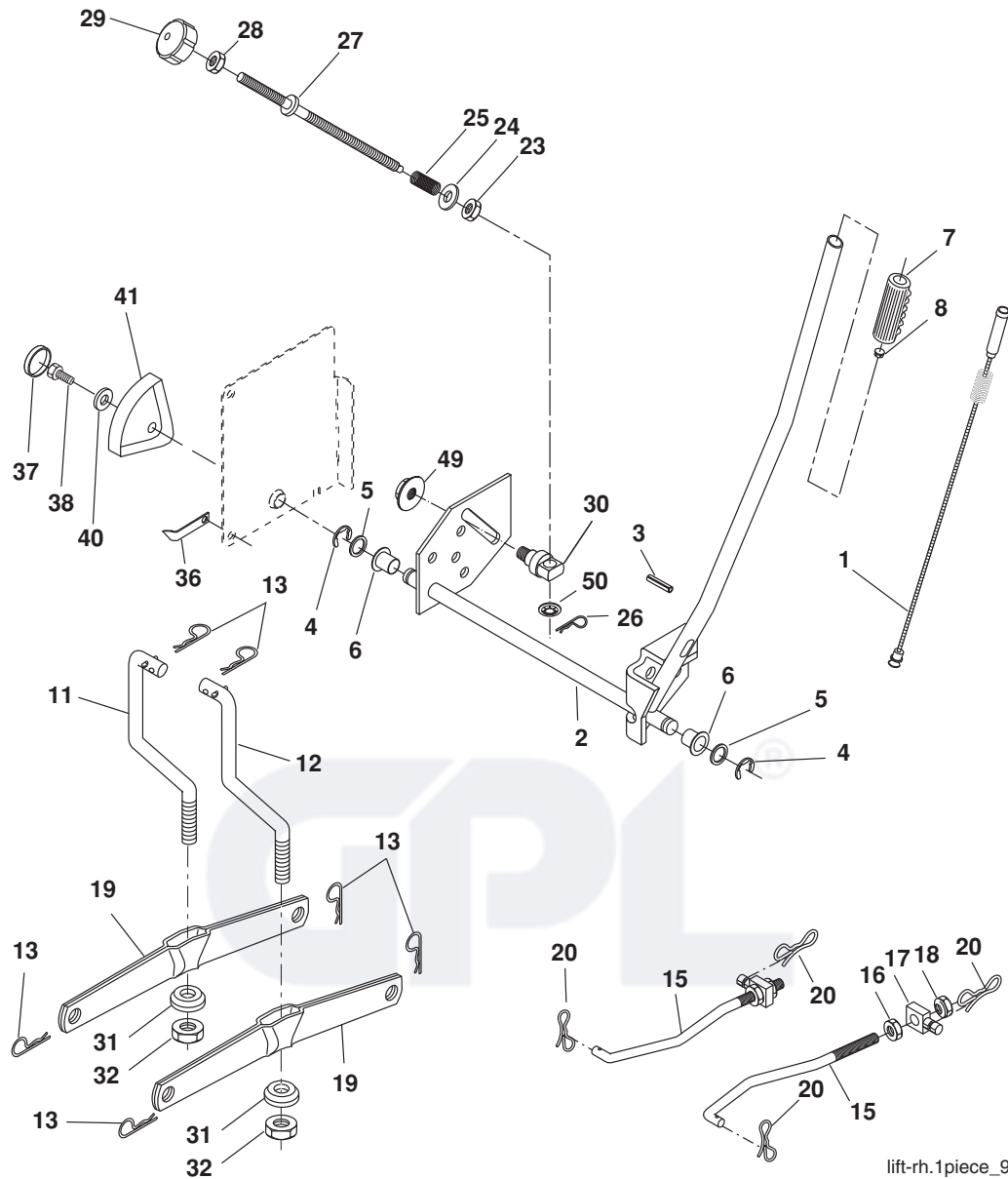

lift-rh.1piece_9

KEY NO.	PART NO.	DESCRIPTION
1	532 19 84-17	Wire Asm Inner Spring w/Plunger
2	532 19 80-70	Shaft Asm. Lift
3	532 18 88-22	Pin Groove
4	812 00 00-02	E Ring #5133-62
5	819 21 16-21	Washer 21/32 x 1 x 21 Ga.
6	532 12 01-83	Bearing Nylon
7	532 12 56-31	Grip Handle Fluted
8	532 12 45-26	Button Plunger Black
11	532 16 58-29	Link Asm Lift LH
12	532 16 58-31	Link Asm Lift RH
13	532 12 46-70	Retainer Spring
15	532 17 32-88	Link Front
16	873 35 08-00	Nut Jam Hex 1/2-13 unc
17	532 17 56-89	Trunnion Blk Zinc
18	873 80 08-00	Nut Lock w/Wsh 1/2-13 unc
19	532 13 98-68	Arm Suspension Mower
20	532 19 42-09	Pin Cotter 7/16 Bowtie Lock
23	532 11 08-07	Nut Special
24	819 13 10-16	Washer 13/32 x 5/8 x 16 Ga.

KEY NO.	PART NO.	DESCRIPTION
25	532 12 48-74	Spring 2-1/8"
26	532 16 94-84	Retainer Clip
27	532 12 69-71	Rod Adj Lift Zinc 7.49 Wrk Lg
28	873 35 06-00	Nut Hex Jam 3/8-16 unc
29	532 13 80-57	Knob Inf 3/8-16 unc Blk w/sym
30	532 15 02-33	Trunnion Infin Height
31	532 16 98-65	Bearing, Pvt. Lift.
32	873 54 06-00	Nut Crownlock 3/8-24
36	532 15 50-97	Pointer Height Indicator
37	532 12 39-35	Plug Hole Blk 1.485/1.515 Dia
38	817 06 05-16	Screw 5/16-18 x 1
40	819 11 24-10	Washer 11/32 x 1-1/2 x 10 Ga.
41	532 12 39-34	Scale Ind Height Blk
49	532 14 52-12	Nut hex Flange Lock
50	532 11 04-52	Nut Push Phos & Oil

NOTE: All component dimensions given in U.S. inches
 1 inch = 25.4 mm

**TRACTOR - - MODEL NO. LT2216CM (96061019304), PRODUCT NO. 960 61 01-93
BAGGER 46**

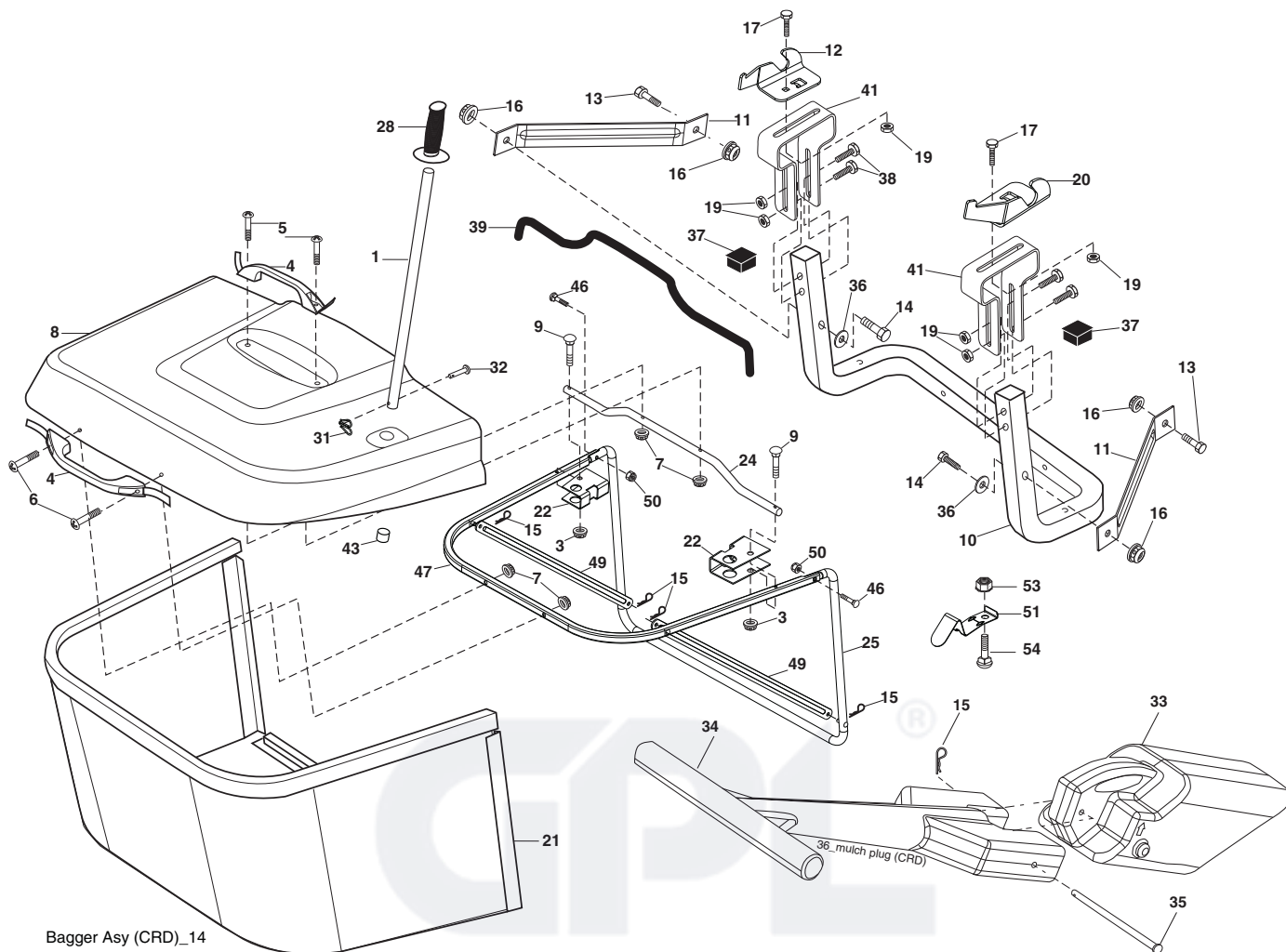

KEY NO.	PART NO.	DESCRIPTION	KEY NO.	PART NO.	DESCRIPTION
1	532 16 52-49	Tube Handle Bagger CRD	31	532 16 94-84	Retainer Clip
3	532 12 39-76	Nut Lock 1/4 Lge Flg Gr. 5 Zinc	32	532 12 68-75	Rivet Rd Hd Drilled 3/8 Dia.
4	532 16 99-16	Handle Bagger w/Lvrs Blk CRD	33	532 16 55-71	Plug Mulcher
5	874 98 10-24	Screw Pan Head #10-24 x 1.50	34	532 16 55-70	Handle Mulcher
6	874 98 10-32	Screw Pan Hd	35	532 16 55-72	Pin Mulcher
7	873 40 10-00	Nut Wiz Lock Hex Serr/Hd 10-24	36	819 13 20-12	Washer 13/32 x 1-1/4 x 12 Ga.
8	532 18 13-54	Cover Bagger	37	532 17 54-01	Plug Support Bagger CRD
9	872 14 04-18	Bolt Carr. 1/4-20 x 2.25d x Gr.5	38	872 01 05-20	Bolt 5/16-18 x 2-1/2
10	532 18 12-82	Tube Support Bagger CRD	39	532 41 62-57	Seal
11	532 16 57-19	Bracket Support Upper Bag CRD	41	532 16 96-83	Bracket Pnt Adj Pvt Bagger CRD
12	532 18 88-48	Bracket Pivot LH	43	532 17 40-83	Plug Tubing End
13	874 76 06-12	Bolt Fin Hex 3/8-16 unc	46	872 11 05-10	Bolt Carr. 5/16-18 x 1-1/4 Gr. 5
14	874 52 06-36	Bolt Fin Hex 3/8-16 x 2-1/4 Gr. 5	47	532 19 37-04	Tube Upper Bagger
15	532 12 46-70	Retainer Spring	49	532 19 33-05	Bar Spreader
16	873 90 06-00	Nut Lock Flange 3/8-16 unc	50	873 80 05-00	Nut Lock Hex w/Ins. 5/16-18 unc
17	872 14 05-06	Bolt Rdhd Sht Sqnk 5/16-18 unc x 3/4	51	532 19 99-03	Latch Spring Bagger
19	873 90 05-00	Nut Lock Hex Flange 5/16-18	53	873 51 04-00	Nut Keps Hex 1/4-20 unc
20	532 18 88-47	Bracket Pivot RH	54	872 14 04-06	Bolt Rdhd Sqnk 1/4-20 x 3/4 Gr. 5
21	532 40 61-80	Bag Asm CRD			
22	532 16 57-81	Bracket Side Bagger CRD			
24	532 16 57-83	Tube Pivot Bagger CRD			
25	532 19 37-05	Tube Front Bagger			
28	532 16 57-87	Grip Handle			

NOTE: All component dimensions given in U.S. inches
1 inch = 25.4 mm